

M60, M90 and M200 Weld Heads



- Proven and very reliable weld head series with minimum cost of ownership delivering maximum reliability and minimum service cost
- Ease of Maintenance provides convenient daily operation and minimum training and technical service efforts
- Modular design allows for easy integration into existing infrastructure
- Three types of weld heads offer maximum flexibility depending on the width of the cylinder.

TYPICAL APPLICATIONS



Automotive



Electronics



IT & Multimedia

CONFIGURATION OPTIONS

The M-Series weld heads are designed to be used in combination with electrodes, force sensors, displacement sensors. Please find more details in the respective Technical Data Sheets of the reference products mentioned.

PRODUCT OVERVIEW

The MIYACHI PECO M-series weld heads are available in three versions:

M-Series	M60 M90 M200	-120N, -185N and -294N -1160N, -H and -K -3000N and -4700N
-----------------	--------------------	--

The M-Series has three main products which come in differing versions each depending on the weld force needed. Product differences for each version are described in the Technical Specifications table below.

TECHNICAL SPECIFICATIONS

	M60	M90	M200
Configuration	with stand and water distributor		with stand and water distributor, circular arms (-3000) or MK1 electrode holders
Options	with quick change holders		various
Electrode Stroke	max 30 mm		max 40 mm
Closing Stroke	pneumatic		
Welding Pressure	pneumatic		
Weld Force	max. 120N/185N/294N	max. 1160N	max. 3000N/ max. 4700N
Air Pressure Supply	max 6 bar		
Weld Force Adjustment	via adjustable pressure control valve or proportional valve		
Electrode Shape	cylindrical, d = 6 mm	cylindrical, d = 10 mm, special electrode needed for -K	cylindrical, d = 10 mm, MK1 electrode needed for -4700
Electrode Holder	quick change holder without anti-torsion protection for electrodes	circular arms, special electrode holder for -K	circular arms, MK1 electrode holder
Weld Cables	2x95 mm ² , 700 mm long	2x500 mm ² , 700 mm long	2x500 mm ² , 700 mm long
Environment Temp.	0-40 °C		
Cooling	-		water-cooled arm holders and circular arms

WEIGHT & DIMENSIONS

	M60	M90	M200
Weight	6 kg w/o secondary cable	14 kg w/o secondary cable	40 kg w/o secondary cable
Dimensions (LxHxD)	190 x 398 x 50 mm	305 x 470 x 96 mm	380 x 565 x 146 mm

M60 SMC-Cylinder		
16 mm 765.32 334 E	20 mm 765.32 335 E	25 mm 765.32 336 E
M90 SMC-Cylinder		
32 mm 765.32 337 E *	40 mm 765.32 338 E *	50 mm 765.32 339 E *
M200 SMC-Cylinder		
32 mm 765.32 337 E *	40 mm 765.32 338 E *	50 mm 765.32 339 E *

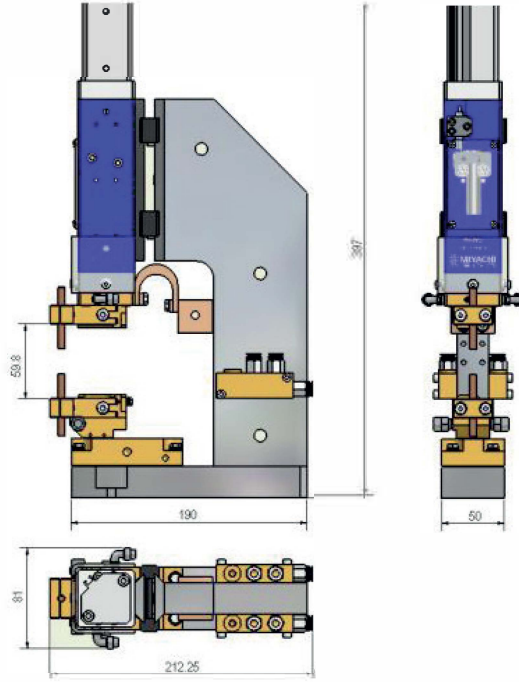

M60

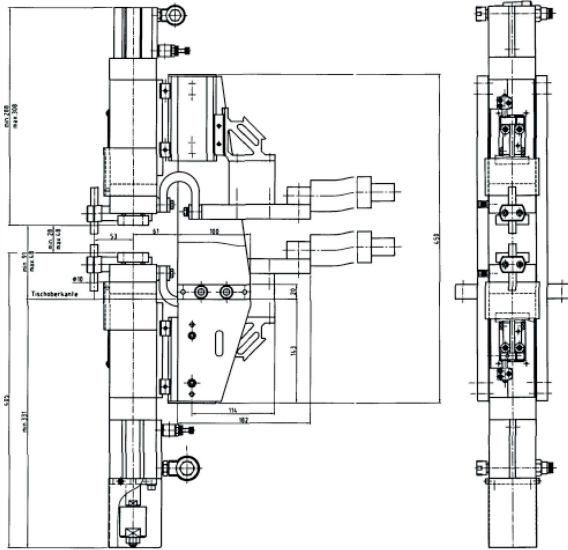

M90-H

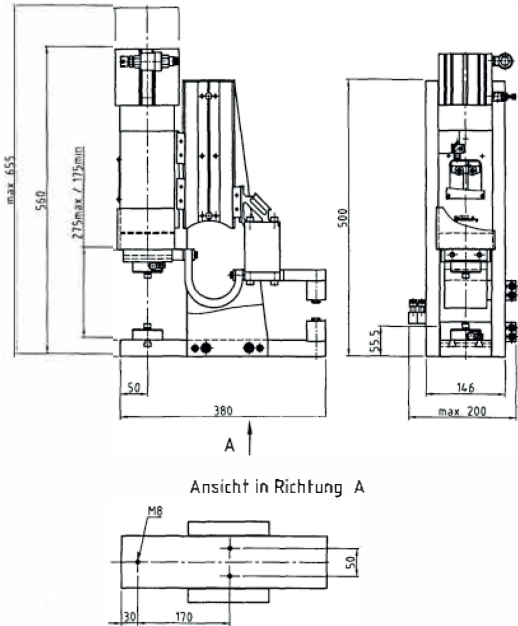

M90-K