



NOVA3 LW Series Laser Welding Workstation

DESCRIPTION

Amada Miyachi Europe offers its expertise to all of its customers to correctly match any welding application with the right laser welder, fibers, optics, tooling and process parameters. The Miyachi laser welders can join a wide range of (stainless) steels, nickel alloys, titanium, aluminum and copper.

Typical laser welding applications include seam sealing of medical devices, High Frequency Aerospace radar components, spot welding of small mechanical parts, battery housings, hermetic seam welding of sensors, batteries, battery packages, etc. Amada Miyachi Europe NOVA3 Series Laser Welding Workstations are modular, flexible, “lean-manufacturing-ready” Class 1 safety enclosures for precision laser spot welding and precision laser seam welding of medical, automotive, electronic and aerospace components as well as a broad range of other industrial applications.

KEY FEATURES

- Modular system adaptable to specific production requirements
- Integrated touchscreen for easy programming
- Class-1 safety enclosure
- Stable platform for laser welds of the highest quality and accuracy
- Fits Miyachi lasers and optics
- Servo motor driven axis (XYZ)
- Several door configurations possible:
Opening direction horizontal or vertical
Actuation method manual, pneumatic or motorised
- Data logging of system messages
- Password controlled user levels
- Ergonomic platform for continuous production and stress-free, concentrated and effective operators
- Produce your parts at an efficient cost point and maximize the profit per product.

APPLICATIONS

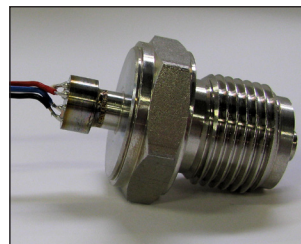

Seam Welding of sensors

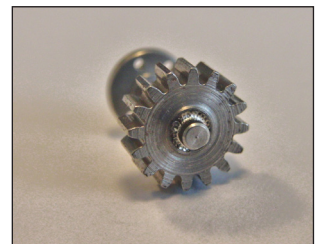

Small precision gears



Seam welding of super capacitors

DESCRIPTION

The NOVA3 is available in five configurations: for Laser Welding, Resistance Welding, Hot Bar Bonding, Laser Marking and Laser Cutting.

For Laser Welding, it can be equipped with Pulsed Nd-YAG lasers up to 600W, Continuous Wave Fiber lasers up to 5000W and Quasi Continuous Wave (Pulsed) Fiber lasers up to 600W average power. Typically these lasers are used for precision spot- or seam welding of metal parts.



OPTIONS

The following options are available:

- CNC module for easy programming of complex contours
- CCTV camera system for parts alignment
- Remote diagnostics by 3G or LAN
- Inline configurations (SMEMA compatible)
- Fourth (rotary) axis in several versions including high speed, high load
- Parts clamping by chucks, collets. Clamping can be operated manual or automatic
- Lathe constructions for positioning, pressing and welding of rotary parts
- Fume extraction and filtration
- Customer specific tooling and parts programming
- Auto-eject of welded parts onto chutes and containers
- Automatic bins for “not OK” parts

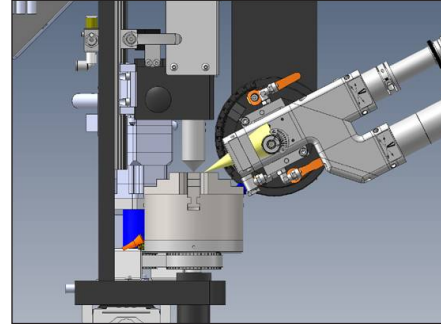

TECHNICAL SPECIFICATIONS

Motion specification X- axis	
Stroke (mm)	330
Repeatability (µm)	±10
Velocity (mm/s)	450
Motion specification Y- axis	
Stroke (mm)	330
Repeatability (µm)	±10
Velocity (mm/s)	450
Motion specification Z- axis	
Stroke (mm)	280
Repeatability (µm)	±20
Velocity (mm/s)	450
Motion specification Rx- axis	
Product dimension diameter x length (mm)	160x180
Static Repeatability (°)	0.2
Velocity (rev/min)	150

TECHNICAL SPECIFICATIONS

Laser Specifications (Pulsed Nd-YAG)	
Average power levels (W)	max. 600
Peak power levels (W)	max. 8000
Peak energy levels (J)	max. 80
Wavelength (nm)	1064 (optional 532nm green for copper welding)
Laserhead	Several options possible, incl. CCTV versions
Collimator lens focal distance (mm)	50 to 200
Focal lens focal distance (mm)	50 to 200
Optical fiber diameter (µm)	100 to 1000
Effective spot sizes (µm)	100 to 1000
Optical fiber length (m)	5 to 40
Laser Specifications (CW Fiber)	
Average power levels (W)	max. 5000
Peak power levels (W)	max. 5000
Beam quality	Several modes available ($M^2=1,1$ to $M^2=9$)
Wavelength (nm)	1070
Laserhead	Several options possible, incl. CCTV versions
Collimator lens focal distance (mm)	35 to 70
Focal lens focal distance (mm)	50 to 200
Optical fiber diameter (µm)	10 to 300
Effective spot sizes (µm)	10 to 600
Optical fiber length (m)	5 to 40
Laser Specifications (QCW Pulsed Fiber)	
Average power levels (W)	max. 600
Peak power levels (W)	max. 6000
Wavelength (nm)	1070
Laserhead	Several options possible, incl. CCTV versions
Collimator lens focal distance (mm)	35 to 70
Focal lens focal distance (mm)	50 to 200
Optical fiber diameter (µm)	not available
Effective spot sizes (µm)	300 to 600
Optical fiber length (m)	not available

WEIGHT & DIMENSIONS

Dimensions HxWxD (mm), excluding laser, chiller and fume extraction unit	2000x890x1050 2340x890x1350 (including light tower and HMI)
Weight (kg)	350 (depending on options)
Maximum inner space HxWxD (mm)	800x600x900 (Z x X x Y direction)
Minimum available space for product HxWxD (mm)	200x300x450 (Z x X x Y direction)